

JULY 5, 2017
WAYNESBORO, PA 17268
REGULAR MEETING

Council President C. Harold Mumma called the regular meeting of the Waynesboro Borough Council to order at 7:22 p.m. (immediately following the public hearing) with the following in attendance:

Council Members – Delmos Oldham, Patrick Fleagle, Niccole Rolls, C. Harold Mumma and Michael Cermak (Chad Rooney was absent)

Mayor Richard Starliper

Borough Staff – Jason Stains, Borough Manager
Denny Benshoff, Maintenance Superintendent
Kevin Grubbs, Head of Engineering Services
Sam Wiser, Borough Solicitor (Salzmann Hughes, PC)
S. Leiter Pryor, Director of Utilities
Jody Sanders, Deputy Fire Chief
John Beck, Assistant Fire Chief

PLEDGE OF ALLEGIANCE: Mayor Starliper led those present in the Pledge of Allegiance.

PRESENTATIONS/PROCLAMATIONS/RECOGNITIONS

Adam Janes – Mr. Janes was present to request written permission for Mid-Atlantic Games to play Amtgard (a medieval fantasy live action roleplay game that uses foam weapons to act out a medieval fantasy experience) at Rotary Park. He noted this is necessary so they can be covered under their insurance (\$3 million general aggregate with \$1 million per occurrence which would protect park property and any visitor to the park). He explained safety measures utilized during the games, adding they (a group of 8-30 maximum) usually meet every Saturday at 1:00 p.m. Council will discuss the matter further later in the meeting.

President Mumma welcomed members of Boy Scout Troop 97, who are attending this meeting for their community merit badge.

David Rosenberger, Brinjac Engineering, Inc. – Mr. Rosenberger gave a PowerPoint presentation on the lighting study conducted by his firm for Main Street from Clayton Avenue to Tritle Avenue (a copy is attached to these minutes as Addendum #1). He discussed the existing conditions and concerns, and presented design options and other ideas to help improve safety along the Main Street corridor. In dealing with the major issue of visibility, their recommendations include:

- Additional poles at mid-block crosswalks
- Combination of existing decorative lights, as well as some overhead cobra lights
- Remote monitoring control systems
- Routine cleaning and periodic light level checks
- Fresh painting of all pavement markings

He presented two (2) options, noting the benefits of both –

Design Option 1 - \$400,000 (using only existing light fixtures)

- Raises light level close to national standard
- Requires significant tree trimming
- Glare improves slightly
- Familiar aesthetic

Design Option 2 - \$700,000 (combination of existing and overhead light fixtures)

- Light level above national standard
- Minimal tree trimming
- Provides good uniformity
- Reduces glare
- Eye drawn to decorative light at lower mounting level
- Maintains Main Street aesthetic

Councilwoman Rolls noted that there are grants available to assist with these improvements, but permission from Council is required first in order to proceed with applying for grant funding for the project. Then, based on the amount of grant money approved, a decision will need to be made on which option to choose. She added that grants of this nature will require 30% matching funds (some of which may also come from other grant sources).

Councilwoman Rolls made a motion to authorize proceeding with seeking grant funding for Option 2. Councilman Cermak seconded; the motion passed unanimously.

EXECUTIVE SESSION: Council adjourned to executive session at 8:20 p.m. and reconvened to regular session at 8:27 p.m.

COMMITTEE REPORTS AND VOTING ON ITEMS FROM COMMITTEE REPORTS (AS NEEDED)

PERSONNEL COMMITTEE: Councilman Cermak acknowledged these actions --

- The hiring of Cody Frey as a Lifeguard at the rate of \$8.70/hour
- The hiring of Matthew Coon, Michael Coon and Christine Coon as Lifeguards at the rate of \$8.25/hour

- Shawn Tuthill's probationary period completion and permanent appointment to Police Officer I, effective 06/27/2017

Councilman Cermak made a motion to approve a step increase for Kevin Grubbs to salary level 19C, effective 06/03/2017. Councilman Oldham seconded; the motion passed unanimously.

Councilman Cermak made a motion to authorize the Council President to approve the Memorandum of Understanding with a uniformed Police Officer. Councilman Oldham seconded; the motion passed unanimously.

PROPERTY AND PUBLIC SAFETY COMMITTEE: No report.

STREET COMMITTEE: Councilwoman Rolls made a motion to approve the installation of a handicapped parking space at 234 Wayne Avenue. Councilman Cermak seconded; the motion passed unanimously.

INTERGOVERNMENTAL COMMITTEE: No report.

DOWNTOWN REVITALIZATION COMMITTEE: No report.

FINANCE COMMITTEE: No report.

RECREATION BOARD: Mr. Stains noted that Adam Janes made a similar presentation to the Recreation Board at their last meeting, and they recommended Council's approval of the request. Accordingly, Councilwoman Rolls made a motion to approve Mid-Atlantic Games' request to play Amtgard at Rotary Park, subject to their following all Park rules established by the Borough of Waynesboro and their naming the Borough of Waynesboro as an additional insured on their insurance policy. Councilman Cermak seconded; the motion passed unanimously.

MAYOR'S REPORT: The Mayor's Report was as follows –

- On June 8th, I attended the Re/Max mixer.
- On June 9th, I attended the Romance Boutique ribbon cutting.
- On June 13th, I attended the Fire Police meeting.
- On June 17th, I attended and participated in Mainstreet's Car Show. Many thanks to all who helped make it a great show with no rain.
- On June 22nd, I attended the Leland Main Street Gala. Thanks to Cathy Baker and Bill Kohler for making it happen.
- On June 23rd, along with Councilman Fleagle, I attended the ribbon cutting for the Morningstar Detail Business.
- On June 24th, I attended and presented retiring Township Manager Mike Christopher with a proclamation.
- On July 4th, I participated in the annual 4th of July parade, sponsored by the Brothers of the Brush. Also thanks to the Jubilee Committee.

SOLICITOR'S REPORT: No report.

DIRECTOR OF UTILITIES' REPORT: No report.

MANAGER'S REPORT: Manager Stains noted the following –

- “Award of Contract for Demolition” should be removed from the Consent Agenda as no bids were received.
- Pursuant to articles in the local newspaper regarding the Firemen's Relief Association, the Borough has received a copy of the Auditor General's report and the Council President, Solicitor and Manager met recently with the President and Treasurer of the Relief Association. He noted they have an action plan in place moving forward which satisfies the Borough's concerns and addresses the issues noted in the AG report.
- Maintenance Department is working again on the walking trail. They are waiting for D. L. George & Sons to deliver the bridge for the middle of the trail, but the stone base will be done throughout the trail within the next several weeks and the entire trail should be completed sometime this summer. He commented that some people are already using the stoned section between the Brimington Development and Renfrew Park.
- The gas furnace project is moving along. The first step was to replace the section of damaged stone wall outside the furnace room. UGI will be running a gas line in the near future, the boiler has been ordered (approved by the Department of Labor and Industry), and it will be installed by Miller Mechanical in plenty of time for cool weather.
- Distributed an update on the pool budget – he noted a profit of \$11,005.49 at the concession stand at this point in time.

PUBLIC COMMENTS – AGENDA ITEMS: Visitors desiring to comment on a particular agenda item will be recognized by the President to speak when the topic is being discussed.

PUBLIC COMMENTS – NON-AGENDA ITEMS: None.

CONSENT AGENDA: Councilman Fleagle made a motion to approve the Consent Agenda, as follows –

- A. Approval of Minutes as Presented (April 19, 2017 – Hearing #1 and Hearing #2)
- B. Accept Reports of the Police Chief for the month of May, 2017; and Fire Chief for the months of April and May, 2017
- C. Pay Bills – Check Details dated 06/07, 06/13, 06/19, 06/26 and 07/03

Councilman Oldham seconded; the motion passed unanimously.

UNFINISHED BUSINESS

AUTHORIZE ADVERTISEMENT OF PROPOSED ORDINANCE RE: ADOPTION OF OFFICIAL MAP: Kevin Grubbs requested Council's authorization to advertise the proposed Official Map Ordinance on 07/17 and 07/24 (a public hearing will be scheduled for 08/02 at 6:30 p.m., and Council will consider the proposed ordinance for adoption at their meeting immediately following the hearing). Councilman Oldham made a motion for approval. Councilwoman Rolls seconded; the motion passed unanimously.

PROPOSED RESOLUTION NO. 2017-06 IN SUPPORT OF LEGISLATION TO CREATE AN INDEPENDENT REDISTRICTING COMMISSION: Mr. Stains noted that Peter Lagiovane made a presentation to Council on 06/07 and requested their approval of a resolution in support of legislation to create an independent redistricting commission. The matter was tabled until this meeting. Councilwoman Rolls made a motion to approve Resolution No. 2017-06, however there was no second and the motion died.

NEW BUSINESS

PROPOSED RESOLUTION RE: MULTIMODAL FUND GRANT PROGRAM: Mr. Stains noted that the Multimodal Fund Grant Program, through the Commonwealth Financing Authority, is currently open and closes on 07/31. GMS Funding Solutions would like to apply for this grant of up to \$1,000,000 (with a 30% match) to construct infrastructure aimed at enhancing pedestrian safety in the Borough, which may include improved street and sidewalk lighting, crosswalks, sidewalks, curbs and/or curb ramps.

In the upcoming month, Councilwoman Rolls, President Mumma, Jason Stains and Kevin Grubbs will be working with Brinjac Engineering to obtain a more accurate project cost for the grant application. In order for it to be competitive, they must focus on pedestrian safety and other aspects of municipal street lighting which may include (1) the installation of curb and sidewalk on Walnut Street between Second and Third Streets in the vicinity of Waynesboro Human Services, (2) the use of special material to be used on the downtown crosswalks to ensure their visibility, (3) completion of the brick sidewalk projects to Broad Street. They are also looking at the possibility of utilizing CDBG funds for some of these projects, which may be considered as part of the required match. Mr. Stains added that the lighting over "Frick Hill" seems to be much brighter than in the downtown, so there is a possibility that they could focus only on the downtown area (between Broad and Franklin Streets) to also decrease the costs of the project.

Councilwoman Rolls made a motion to authorize applying for MMF grant. Councilman Cermak seconded, but stated he doesn't want to cut lighting at all (if/when items need to

be removed because of budgetary constraints) and will vote with that in mind. A vote was then called and the motion passed unanimously.

RESOLUTION NO. 2017-08

A RESOLUTION OF THE COUNCIL OF THE BOROUGH OF WAYNESBORO, FRANKLIN COUNTY, PENNSYLVANIA, EXPRESSING ITS SUPPORT FOR THE WAYNESBORO PEDESTRIAN SAFETY PROJECT, AND AUTHORIZING THE PREPARATION AND SUBMISSION OF AN APPLICATION FOR GRANT FUNDING THROUGH THE COMMONWEALTH FINANCING AUTHORITY'S MULTIMODAL TRANSPORTATION FUND PROGRAM, AS THE APPLICANT, AND DESIGNATING OFFICIALS TO EXECUTE ALL GRANT DOCUMENTS.

Complete copy on file at Borough Hall.

PROPOSED RESOLUTION RE: AUTHORIZATION FOR FRANKLIN COUNTY TOURISM GRANT: Mr. Stains requested Council's authorization to apply through the Franklin County Tourism and Life Enhancement Grant Program for \$100,000 to connect the Borough's walking trail to Otterbein Park via a dedicated bicycle/walking path through Renfrew Park. Dade Royer (Executive Director at Renfrew) has been working with Kevin Grubbs to formulate the route, and he was also present at this meeting to support the effort. Mr. Stains noted that the Borough is applying for the grant, as they own the Renfrew property. Councilman Cermak made a motion for approval. Councilwoman Rolls seconded; the motion passed unanimously.

RESOLUTION NO. 2017-09

A RESOLUTION OF THE COUNCIL OF THE BOROUGH OF WAYNESBORO, FRANKLIN COUNTY, PENNSYLVANIA, EXPRESSING ITS SUPPORT FOR THE RENFREW MUSEUM AND PARK WALKING TRAIL PROJECT, AND AUTHORIZING THE PREPARATION AND SUBMISSION OF AN APPLICATION FOR GRANT FUNDING THROUGH THE FRANKLIN COUNTY TOURISM AND QUALITY OF LIFE ENHANCEMENT GRANT PROGRAM, AS THE APPLICANT, AND DESIGNATING OFFICIALS TO EXECUTE ALL GRANT DOCUMENTS.

Complete copy on file at Borough Hall.

APPROVAL OF CONTRACTOR FOR MAIN STREET CROSSWALK WORK: Kevin Grubbs noted that discussions have been held regarding the damaged brick crosswalks downtown, and it is his recommendation to remove the brick design and replace it with asphalt. He has requested three (3) competitive estimates, however only one (1) was received from AAA Paving (for a total of \$19,500). Councilman Cermak made a motion for approval. Councilman Oldham seconded; the motion passed unanimously.

POLICE DEPARTMENT'S REQUEST RE: NATIONAL NIGHT OUT (AUGUST 1, 2017 – 6:30 TO 8:30 P.M.): Mayor Starliper submitted a request for the Police Department's

annual "National Night Out" event to be held at Memorial Park on 08/01 from 6:30 to 8:30 p.m. Their request includes the blocking off of Memorial Park Drive from Walnut to S. Broad Streets. Councilman Cermak made a motion for approval. Councilman Oldham seconded; the motion passed unanimously.

PROPOSED RESOLUTION NO. 2017-07 RE: SALE OF MUNICIPAL VEHICLES: Mr. Stains presented proposed Resolution No. 2017-07 to authorize the sale of three (3) used vehicles. He noted that Council previously authorized the sale of two (2) police cars, and they would like to sell all the vehicles at the same time (when the new police vehicles are ready for service, which will be either late summer or early fall). Councilman Cermak made a motion for approval. Councilman Oldham seconded; the motion passed unanimously.

RESOLUTION NO. 2017-07

RESOLUTION OF THE BOROUGH OF WAYNESBORO AUTHORIZING THE SALE OF MUNICIPAL PROPERTY

Complete copy on file at Borough Hall.

FOR INFORMATION ONLY

MEMORIAL PARK PROJECT (RESTROOM AND AMPHITHEATER): Mr. Stains noted that the Recreation Board reviewed proposed designs for the restrooms and amphitheater at Memorial Park at their 06/28 meeting, and YSM is currently working on preparing better price estimates based on their choices. He explained that the amphitheater may not necessarily happen with this grant process (depending on cost), and their main priority is the restrooms, followed by the tennis courts and basketball/volleyball area. Denny Benshoff has provided estimates for the maintenance crew to demolish the restrooms and tennis courts, so that cost (approximately \$8,000) can be used as in-kind match. They are hopeful that the contractor will be able to begin construction on the restrooms during the winter so they are ready for spring; and then they can work on the tennis courts and basketball/volleyball courts in the spring.

Councilman Fleagle asked when the proposed plans will be brought to Council, and Mr. Stains noted that a total package will be put together and presented to Council in approximately August.

PRESS QUESTIONS:

Jennifer Fitch, Herald Mail

Question: Are the remaining Council members (those who didn't meet with the Relief Association) confident in the fiduciary responsibility of the Firemen's Relief Association?

- Councilman Fleagle noted that the Relief Association took the findings very seriously, as well as Borough Council, and they developed a plan of action which we are confident will prevent these issues from occurring again.

Question: Regarding the motion for Fair Districts PA legislation dying, what prompted Council as a whole to not pass that resolution?

- President Mumma stated that a motion was made and there was no second. When asked if any Council members wished to state why they didn't second the motion, there was no response.

COUNCIL AND STAFF COMMENTS: Councilman Cermak welcomed the Boy Scouts from Troop 97.

Kevin Grubbs noted that, every 90 days Council must approve an update to the Traffic and Parking Regulations, which will currently expire on 07/19. Councilwoman Rolls made a motion for approval. Councilman Fleagle seconded; the motion passed unanimously.

Bill Kohler (Mainstreet Waynesboro, Inc.) reported that work on the parklet continues, with hopes of the construction being completed near the beginning of August. He noted that they have optimistically scheduled events at the parklet in late August. Mr. Kohler also announced that Mainstreet Waynesboro is selling t-shirts as a fundraiser for the cost of \$15.

Councilman Oldham thanked the Boy Scouts for their attendance.

Councilman Fleagle also thanked the Boys Scouts for attending, adding that he hopes to see them back some day as Eagle Scouts.

Mayor Starliper echoed those comments. He also reported that correspondence has been received from PEMA's Director regarding Mike Bock's official appointment as the Borough's Emergency Management Coordinator. In addition, he asked for an update from Dan Sheffler on several properties he had noted concern about; and Manager Stains advised that notices of violation have been sent to all.

Having no further business to discuss, the meeting adjourned at 9:18 p.m. on a Cermak/Oldham motion which passed unanimously.

Respectfully Submitted,

Melinda S. Knott
Borough Secretary

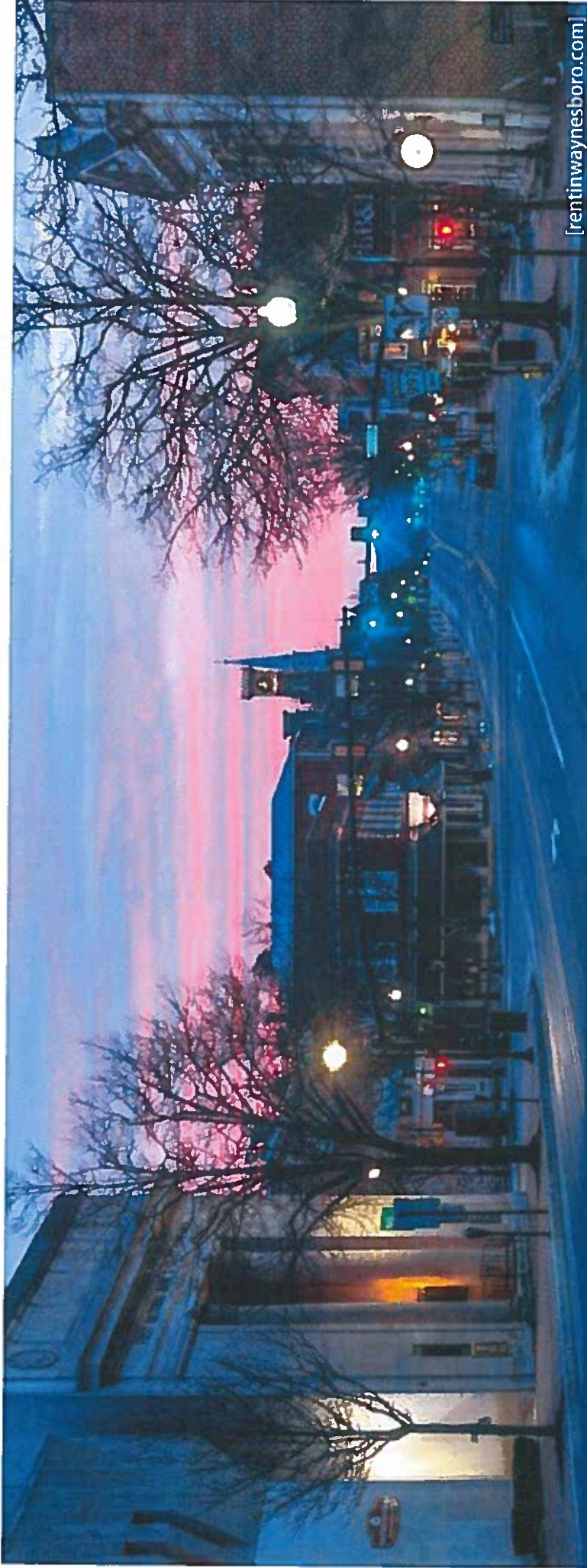

[rentinwaynesboro.com]

Waynesboro

Street Lighting Existing Conditions & Design Concepts

Brinjac Lighting Studio



Main Street Lighting Can be Improved Through Lighting Fixture & Environmental Upgrades

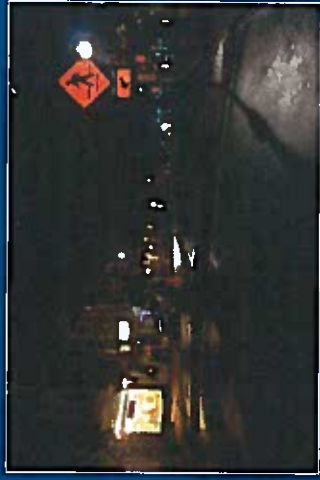

Existing conditions



Design Options



Additional Improvements

Main Street Has Visibility Issues Because of Low Light Levels

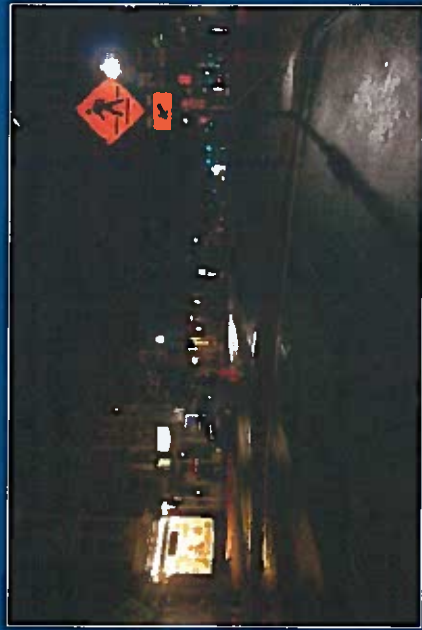
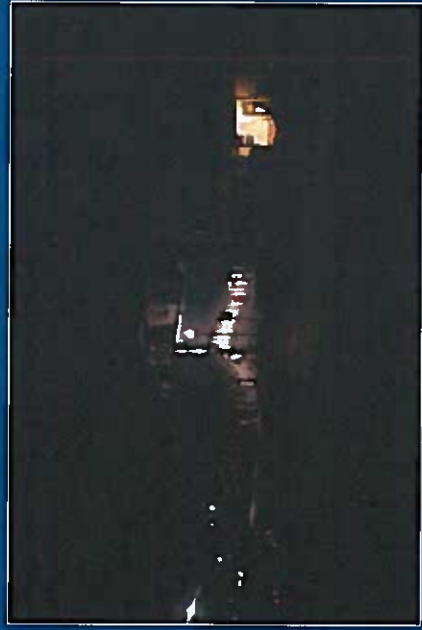

Main Street Has Lower Light Levels Than the Nationally Recommended Minimum

■ Light Level

■ Recommended Light Level

■ Recommended Light Level

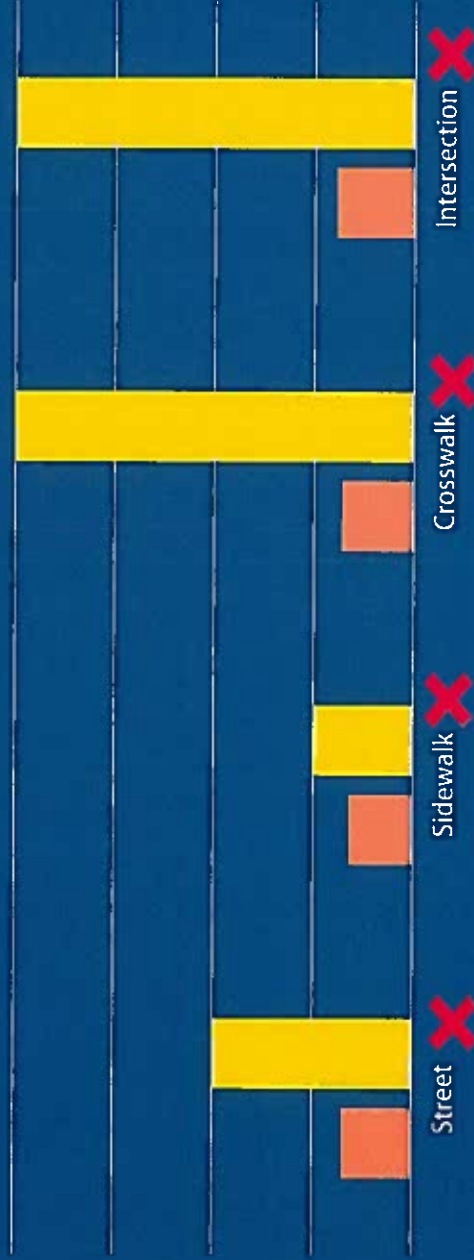

Low light Levels

- Lack of Light
- Depreciation
- Obstructions

Low Light Levels Are a Result of Low Target Levels, Depreciation & Obstructions

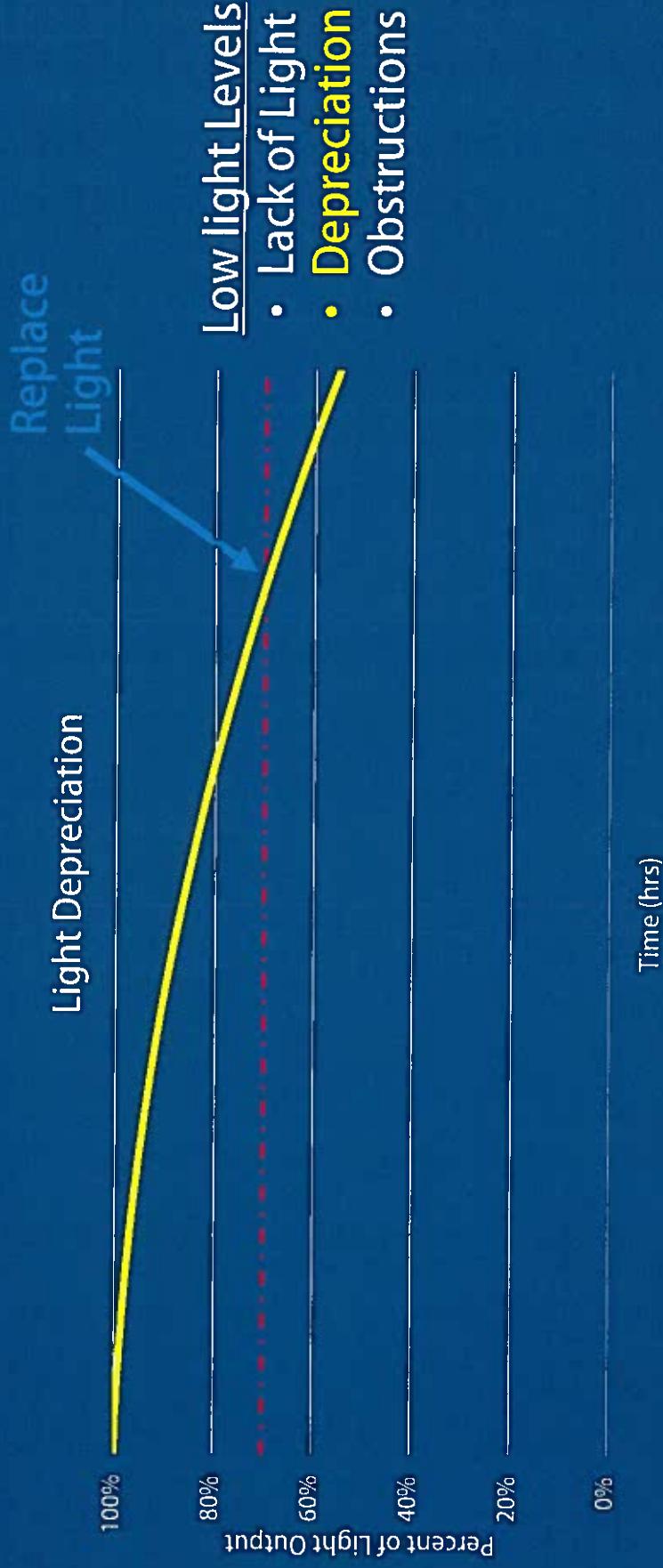

Low Light Levels Are a Result of Low Target Levels, Depreciation & Obstructions

As Branches Grow, they block the light



1. Creates Dangerous Environment
2. Wastes Energy
3. Hides the Decorative Element

Low light Levels

- Lack of Light
- Depreciation
- **Obstructions**

Beauty & Performance are Key Components in New Design



Wires Everywhere



Cobra Head Fixtures



Decorative Fixtures

Performance + Aesthetics = New Design

Increasing Light Levels Improves Visibility & Sense of Safety

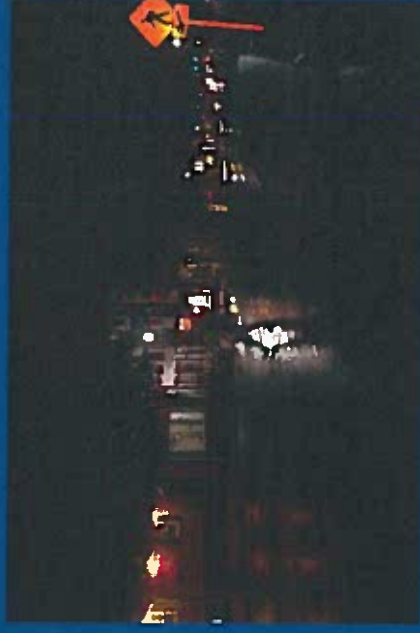
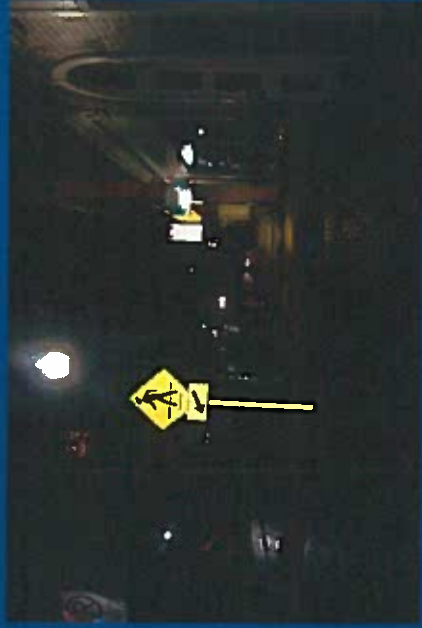

Horizontal
Illumination



Vertical
Illumination

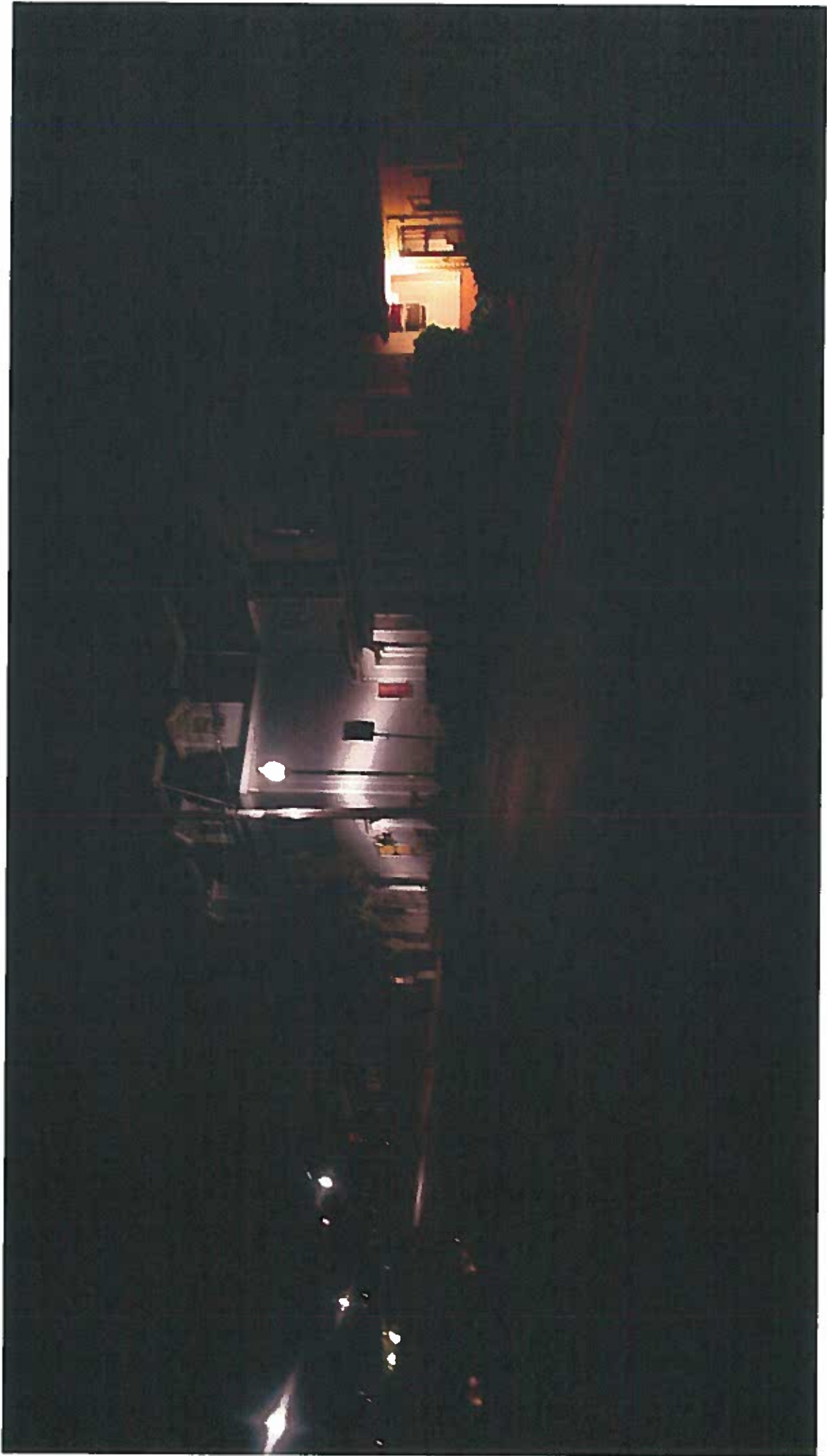

Additional Poles Increase the Light Level & Improve Visibility at Mid-Block Crosswalks

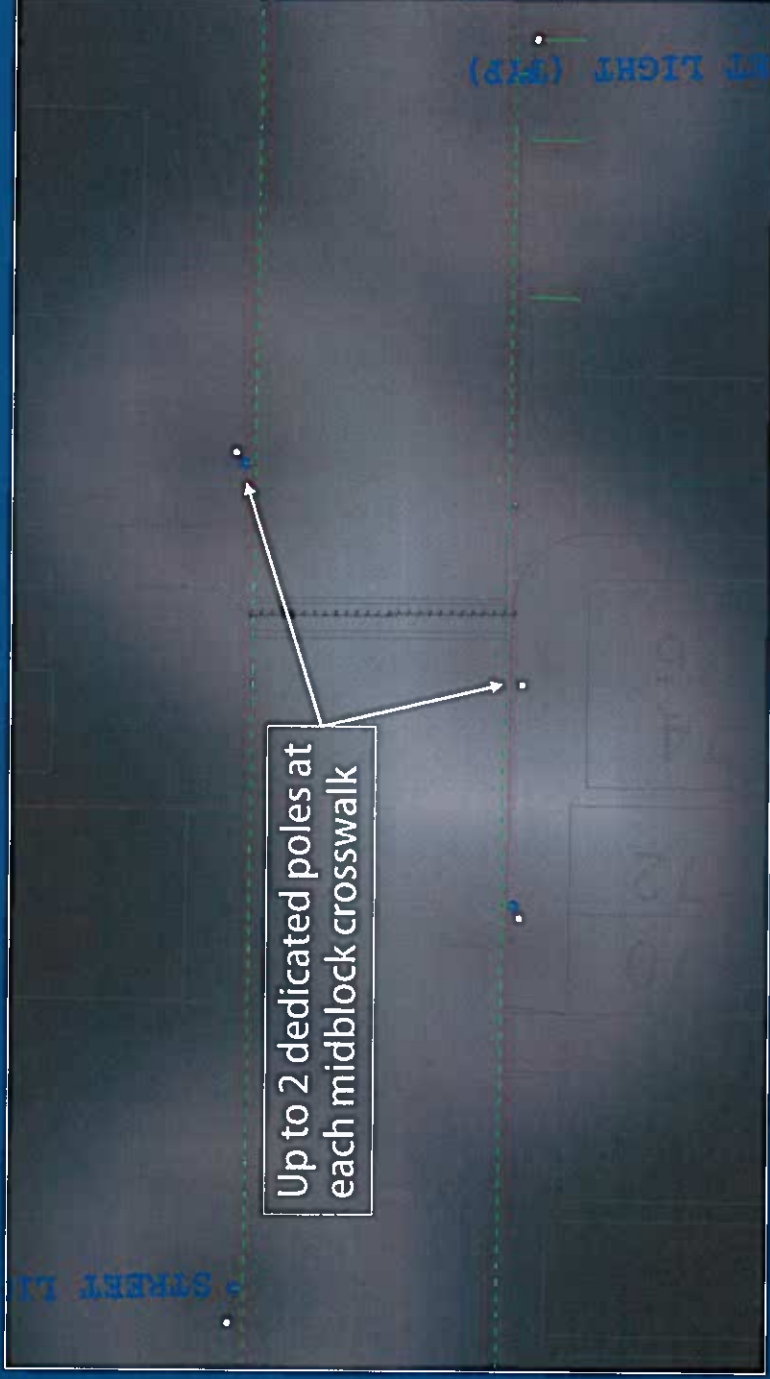

Additional Poles Increase the Light Level & Improve Visibility at Intersections

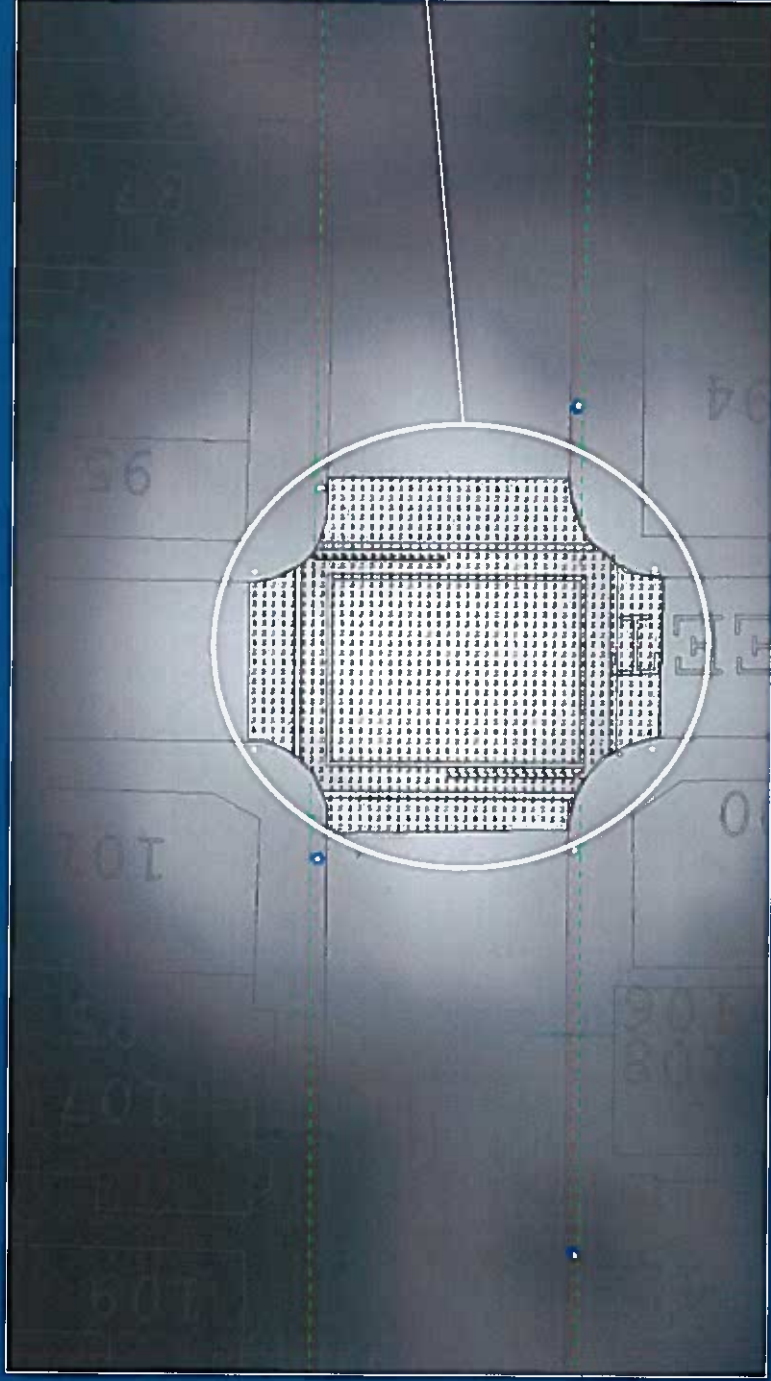

Additional pole locations



Potomac and Main - **B&E**erre

Wireless Monitoring Control System Saves Energy and Maintenance Costs

Remote Monitoring and Control

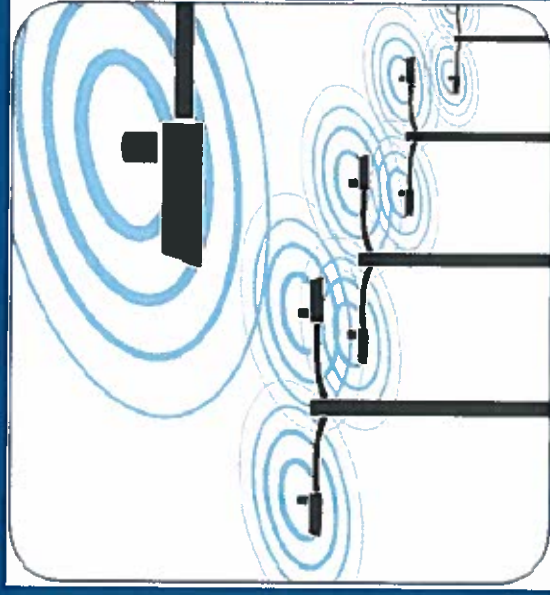

Maintained illumination levels – energy savings.
Burn hours and on/off status – maintenance savings.

Regular Maintenance/Observations



Routine cleaning cycle.
Periodic light level checks.

Both Design Options Use Existing Pole Locations

Design Option 1
Replace Post top
Luminaires with LED



Design Option 2
Replace Poles with
Pedestrian & Roadway
LED Luminaires



LED Replacement Keeps the Same Look of Main Street But Does Not Improve Light Level to National Standards



LED Replacement

LED Replacement Keeps the Same Look of Main Street But Does Not Improve Light Level to National Standards



LED Replacement

Requires Significant Tree Trimming

LED Replacement Keeps the Same Look of Main Street But Does Not Improve Light Level to National Standards

■ Design Option 1

■ Main Street Light Levels

■ Recommended Light Level

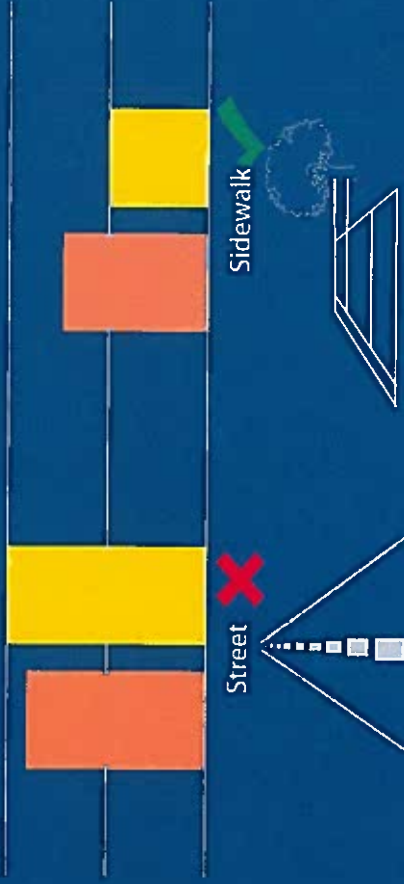

LED Replacement

LED Replacement Keeps the Same Look of Main Street But Does Not Improve Light Level to National Standards



LED
Replacement

Pedestrian & Performance Lighting Maintains the Look of Main St. While Bringing Light Levels to National Standard

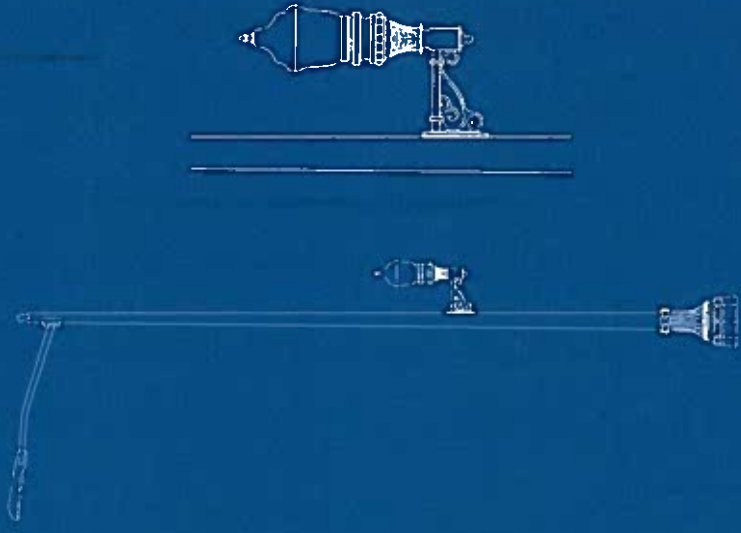

Pedestrian & Performance Lighting Maintains the Look of Main St. While Bringing Light Levels to National Standard

■ Design Option 2

Main Street Light Levels ■ Recommended Light Level

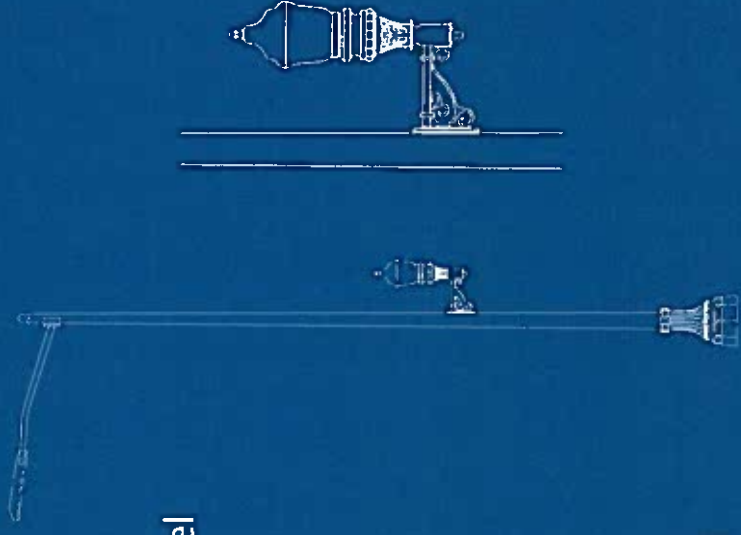
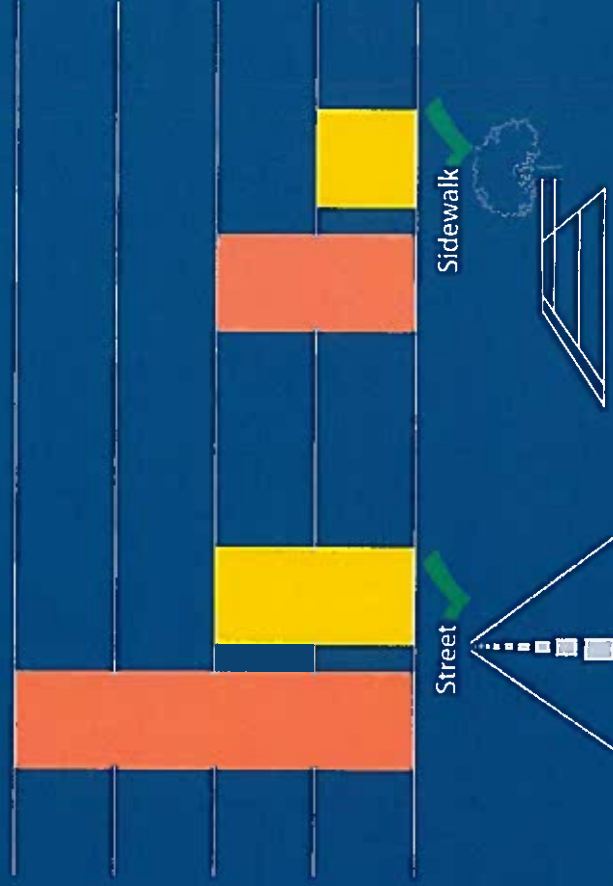

Design Option 2 Provides Better Performance While Maintaining the Aesthetic of Main Street



Design Option 1

- Raises Light Level Close to National Standard
- Requires Significant Tree Trimming
- Glare Improves Slightly
- Familiar Aesthetic

\$400,000



Design Option 2

- Light Level Above National Standard
- Minimal Tree Trimming
- Provides Good uniformity
- Reduces Glare
- Eye Drawn to Decorative Light at Lower Mounting Level
- Maintains Main St. Aesthetic

\$700,000

Repainting Pavement Markings, Like Crosswalks Can Improve Visibility & Road Aesthetic



Additional Poles Can Increase the Light Level & Improve Visibility at Intersections

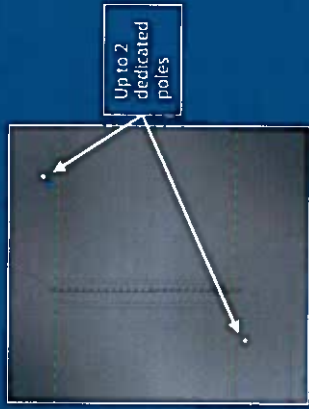

Improvements

Dedicated Midblock
Crosswalk & Intersection
lighting



Design Option 1

Replace Post top
luminaires with LED



Design Option 2

Replace Poles with
Pedestrian & Roadway
LED Luminaires



Repaint

Repaint
Pavement
Markings

THANK YOU!

Design Criteria

Design criteria must meet Recommended Standards



Street Lighting
 0.9 cd/m² Average Luminance
 3.0 : 1 Avg./Min. Luminance Ratio
 5.0 : 1 Max./Min. Luminance Ratio
 0.3 : 1 Max. Veiling Luminance Ratio

Existing **Recommended**

Avg. cd/m² 0.45 **X** 0.9

Avg./Min cd/m² 4.5 **X** 3



Sidewalk Lighting
 0.5 fc Average Illuminance
 0.2 fc Min. Illuminance
 4.0 : 1 Avg./Min. Illuminance Ratio

Regulating Organizations



Avg./Min Fc
 West Main Street is considered a Medium Pedestrian Conflict-Area

0.32 **X**
 3 **✓**

Min. Fc (midblock) 0.36 **X**



Crosswalk Lighting
 Midblock
 2 fc Min. at 5ft above pavement
 Intersection
 3.0 fc Min. at 5ft above pavement

American Association of State Highway & Transportation Officials (AASHTO)

Illuminating Engineering Society (IES) **0.27 X**



Intersection Lighting

Major/Collector
 2.6 fc Avg. Illuminance
 3.0 : 1 Avg./Min. Illuminance Ratio
 Major/Local
 2.0 fc Avg. Illuminance
 3.0 : 1 Avg./Min. Illuminance Ratio

Avg. Fc 0.39 **X** 2.0

Avg./Min Fc 2.2 **✓** 3

